

NOTES:

- ① ANODIZE BLUE PER XYZ-50.
- ② BREAK ALL SHARP EDGES TO .05
- ③ INSPECT PER XHJ-5250.

REVISIONS				
ZONE	REV.	DESCRIPTION	DATE	APPROVED

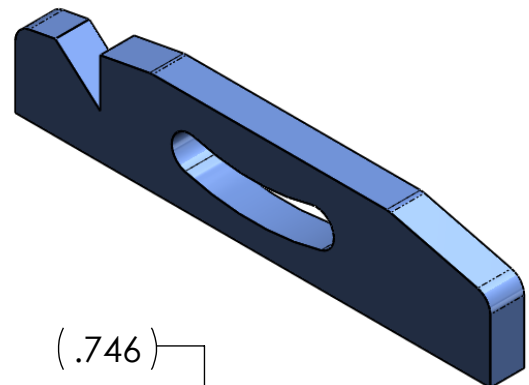
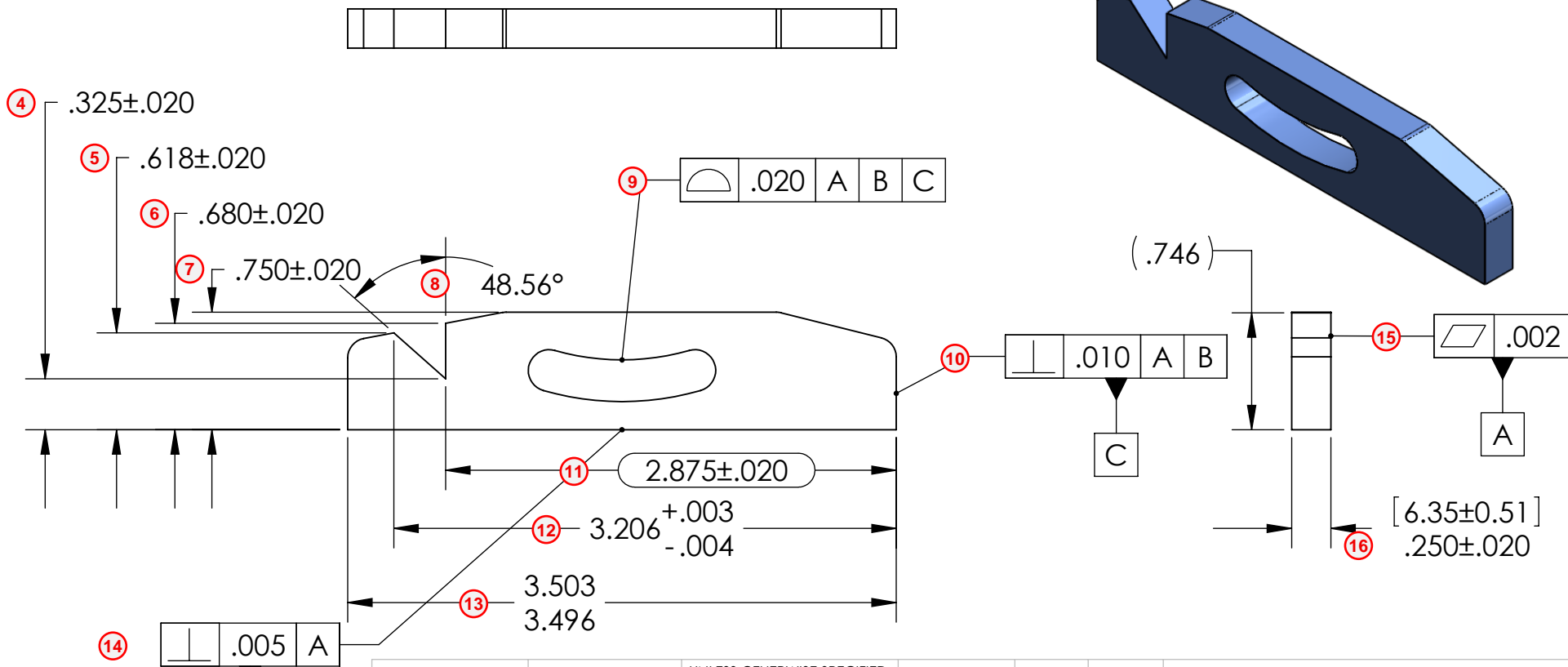

PROPRIETARY AND CONFIDENTIAL
 THE INFORMATION CONTAINED IN THIS DRAWING IS THE SOLE PROPERTY OF <INSERT COMPANY NAME HERE>. ANY REPRODUCTION IN PART OR AS A WHOLE WITHOUT THE WRITTEN PERMISSION OF <INSERT COMPANY NAME HERE> IS PROHIBITED.

		UNLESS OTHERWISE SPECIFIED:	NAME	DATE
		DIMENSIONS ARE IN INCHES	DRAWN	
		TOLERANCES:	CHECKED	
		FRACTIONAL ±	ENG APPR.	
		ANGULAR: MACH ± BEND ±	MFG APPR.	
		TWO PLACE DECIMAL ±	Q.A.	
		THREE PLACE DECIMAL ±	COMMENTS:	
		INTERPRET GEOMETRIC TOLERANCING PER:		
		MATERIAL		
		FINISH		
NEXT ASSY	USED ON			
APPLICATION		DO NOT SCALE DRAWING		

SolidWorks Inspection		
TITLE:		
PLATE - LOWER		
SIZE	DWG. NO.	REV
A	PRT-MFG-237465	A.2
SCALE: 1:1		